

Recurrent Neural Networks

COMP 4630 | Winter 2026

Charlotte Curtis

Overview

- Dealing with sequence data
- Feedforward vs recurrent networks
- References and suggested reading:
 - [Scikit-learn book](#): Chapter 15
 - [Deep Learning Book](#): Chapter 10

Sequence data

- So far we've been talking about images, tabular data, and other "static" data
- ? What are some examples of sequence data?

$$y[n] = \begin{cases} \frac{y[n-1]}{2} & \text{if } n \text{ is even} \\ 3y[n-1] + 1 & \text{if } n \text{ is odd} \end{cases}$$

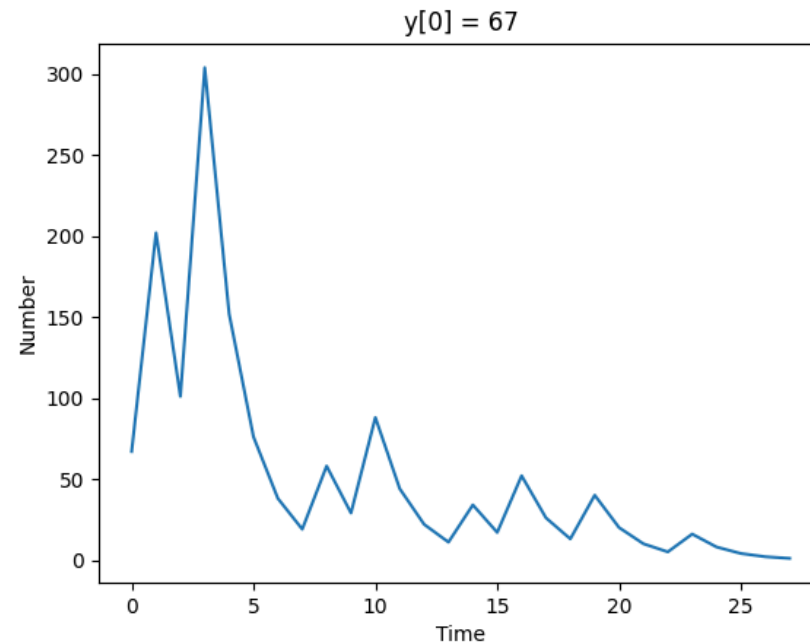

Non-RNN Approaches

As usual, you don't always need a deep learning solution 🛠️

- ? What is an example of a "naive" approach?
- ? What are some limitations of naive approaches?

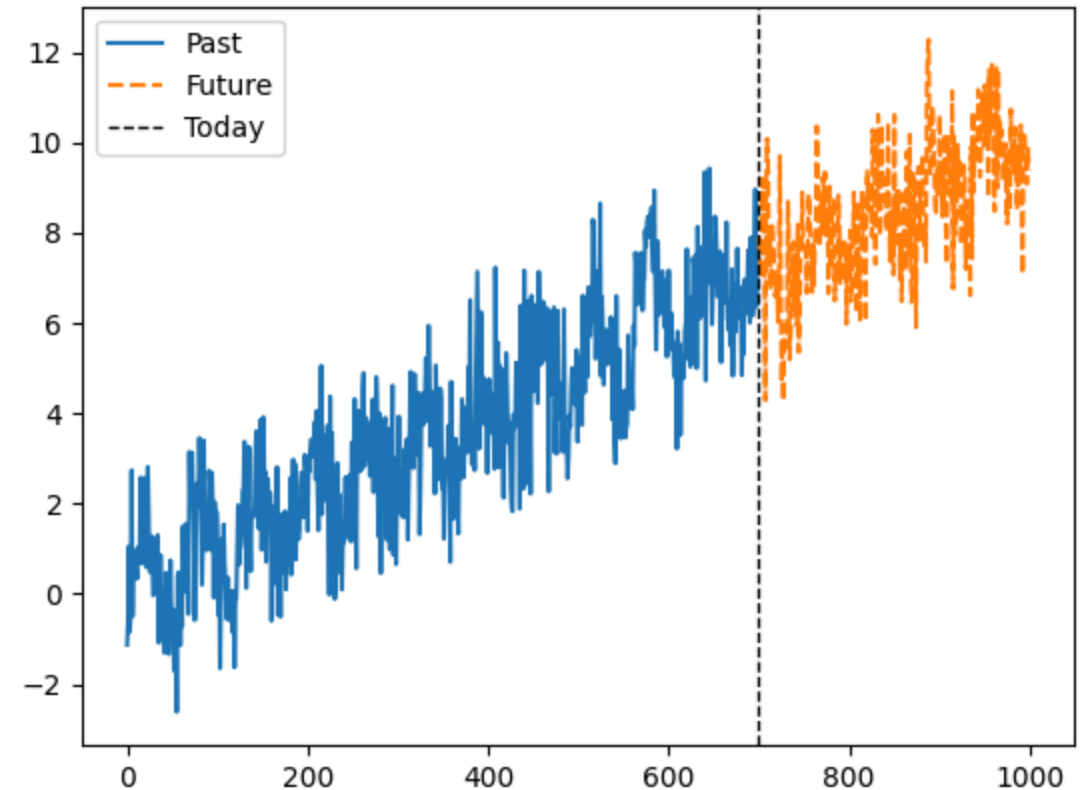

Autoregressive Moving Average

- Models to predict time series with a weighted average of past value

$$\hat{y} = \sum_{i=1}^p \alpha_i y_{t-i} + \sum_{i=1}^q \theta_i \epsilon_{t-i}$$

where $\epsilon_t = y_t - \hat{y}_t$

- Key assumption: data is **stationary** (mean and variance don't change)
- ARIMA adds on "integration" or "differencing" to account for trends

ARIMA

- **Autoregressive** parameter p : How many steps back to average?
- **Moving average** parameter q : How many previous errors to average?
- **Integrative** parameter d : How many "differencing" rounds to perform before applying ARMA?

| *d can be thought of as approximating the d^{th} order polynomial*

Trends, Seasonality, and Assumptions

- ? Are there any obvious trends in the data?
- ? What about non-obvious trends?
- ? How might this dataset be treated differently from the previous one?

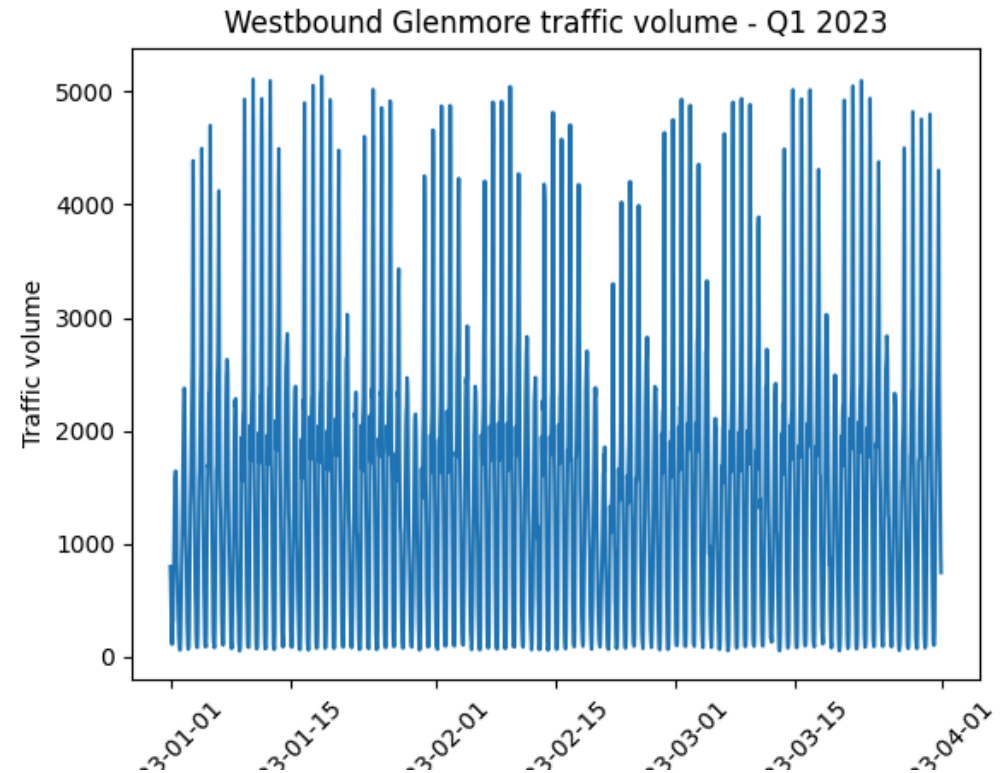

Feedforward vs recurrent networks

- Feedforward: data flows in one direction (then backpropagated)
- Recurrent: data can flow in loops

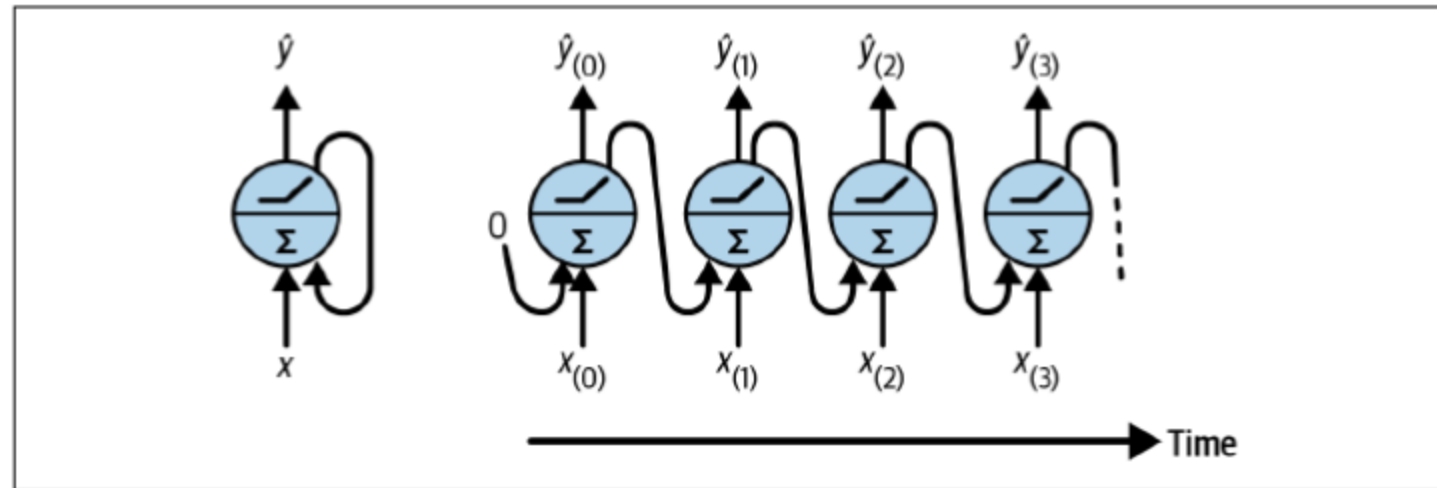

Figure 15-1. A recurrent neuron (left) unrolled through time (right)

Recurrent layers

- The simplest recurrent layer has a single feedback connection

$$\hat{\mathbf{y}}_t = f(\mathbf{W}_x^T \mathbf{x}_t + \mathbf{W}_{\hat{y}}^T \hat{\mathbf{y}}_{t-1} + \mathbf{b})$$

where f is the activation function and \mathbf{W}_x and $\mathbf{W}_{\hat{y}}$ are weight matrices

- "Backpropagation through time" (BPTT) is exactly the same as regular backpropagation through the **unrolled** network
- ? What kind of issues might arise during training?
- ? What are some limitations of this approach?
- ? How can we deal with \mathbf{y}_{t-1} for $t = 0$?

Preparing data for RNNs

- The data format depends on the task, e.g. do you want to predict:
 - The next value in a sequence (e.g. predictive text)
 - The next n values in a sequence (e.g. stock prices)
 - The next sequence in a set of sequences (e.g. language translation)
- Let's start with predicting the next value in a sequence

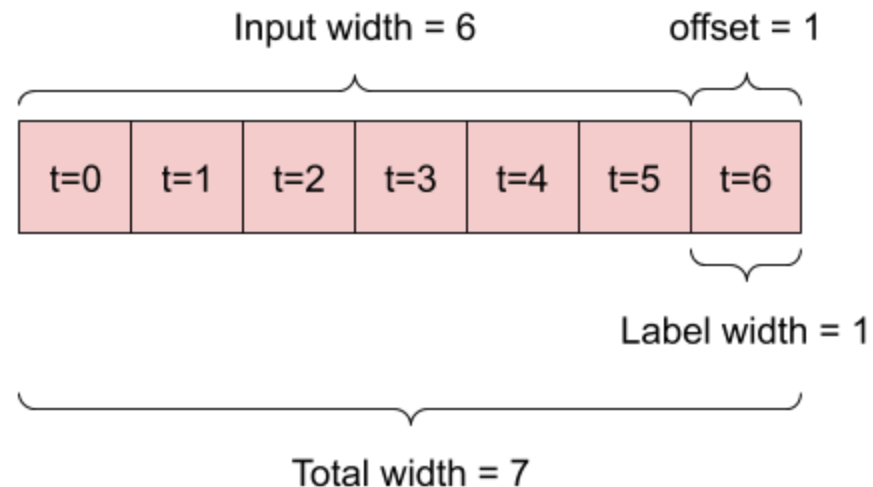

Activation Functions for RNNs

- The default activation function in tensorflow/PyTorch is `tanh`
- ? What is different about RNNs that might influence the choice of activation function?
- ? How might we normalize sequence data?

Beyond the "next value"

- Option 1: Use the single-prediction RNN repeatedly
- Option 2: Train the RNN to predict multiple values at once
 - Easy change model-wise, but data preparation is trickier
 - `n` inputs, `n` outputs
- Option 3: Use a "sequence to sequence" model
 - Even trickier data preparation, but `n` inputs are predicted at each time step instead of just at the end

Seq2seq input/target examples

n	Input	Target
1	[0, 1, 2]	[1, 2, 3]
2	[0, 1, 2]	[[1, 2], [2, 3], [3, 4]]
3	[0, 1, 2]	[[1, 2, 3], [2, 3, 4], [3, 4, 5]]

Problems with long sequences

- Gradient vanishing/exploding
 - Choose activation functions and initialization carefully
 - Consider "Layer normalization" (across features)
- "Forgetting" early data
 - Skip connections through time
 - "Leaky" RNNs
 - Long short-term memory (LSTM)
- Computational efficiency and memory constraints
 - Gated recurrent units (GRUs)

Skip connections and leaky RNNs

- Simple way of preserving earlier data:
- Vanilla RNN: $h^{(t)}$ depends on $h^{(t-1)}$ only
- Skip connection: $h^{(t)}$ depends on $h^{(t-1)}$, $h^{(t-2)}$, $h^{(t-n)}$, etc.
- Leaky RNN has a smooth "self-connection" to dampen the exponential:

$$h^{(t)} = \alpha h^{(t-1)} + (1 - \alpha)h^{(t)}$$

- Not common approaches anymore, as LSTM, GRU, and especially attention mechanisms are more popular

Long Short-Term Memory (LSTM)

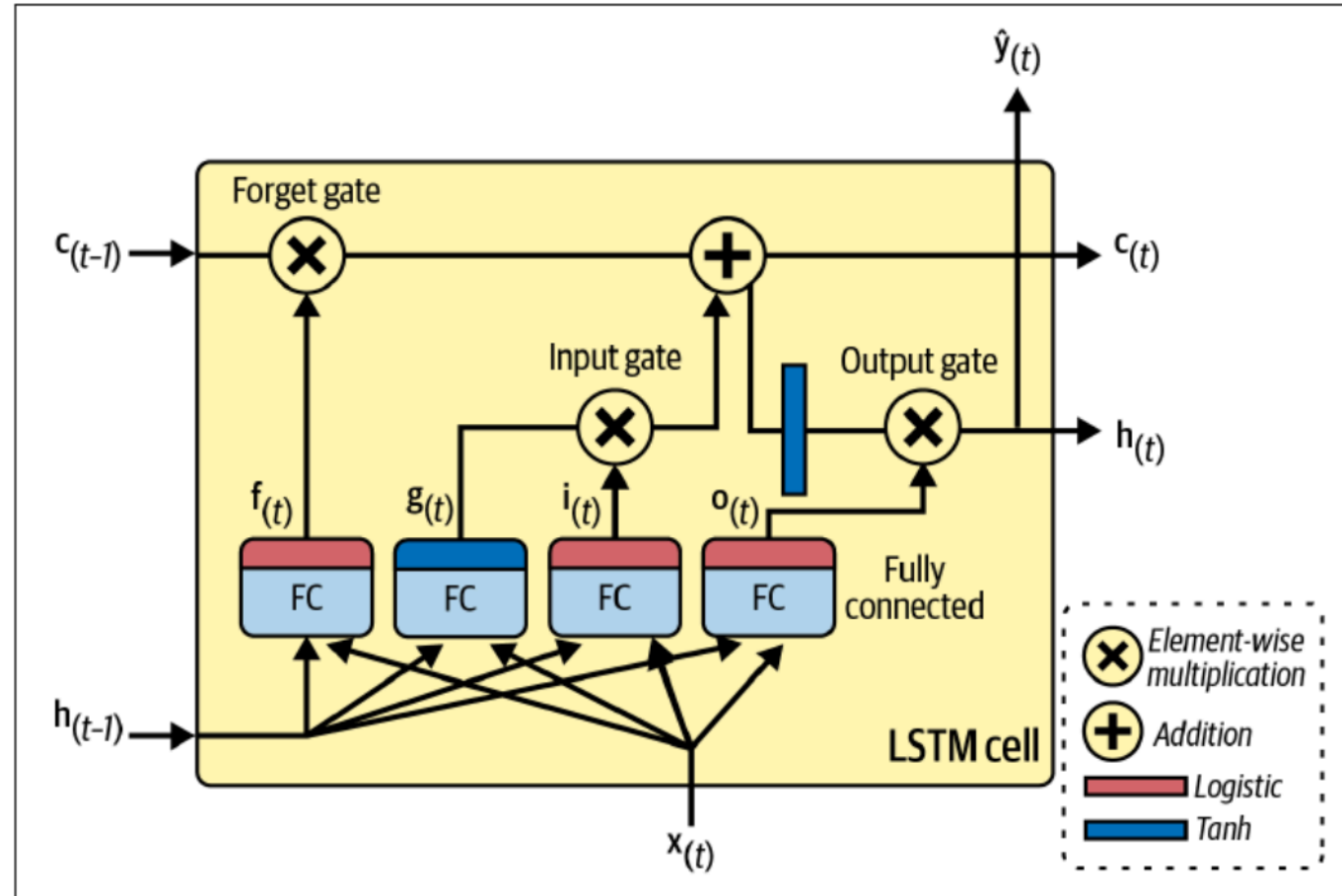

Figure 15-12. An LSTM cell

Gated Recurrent Units (GRUs)

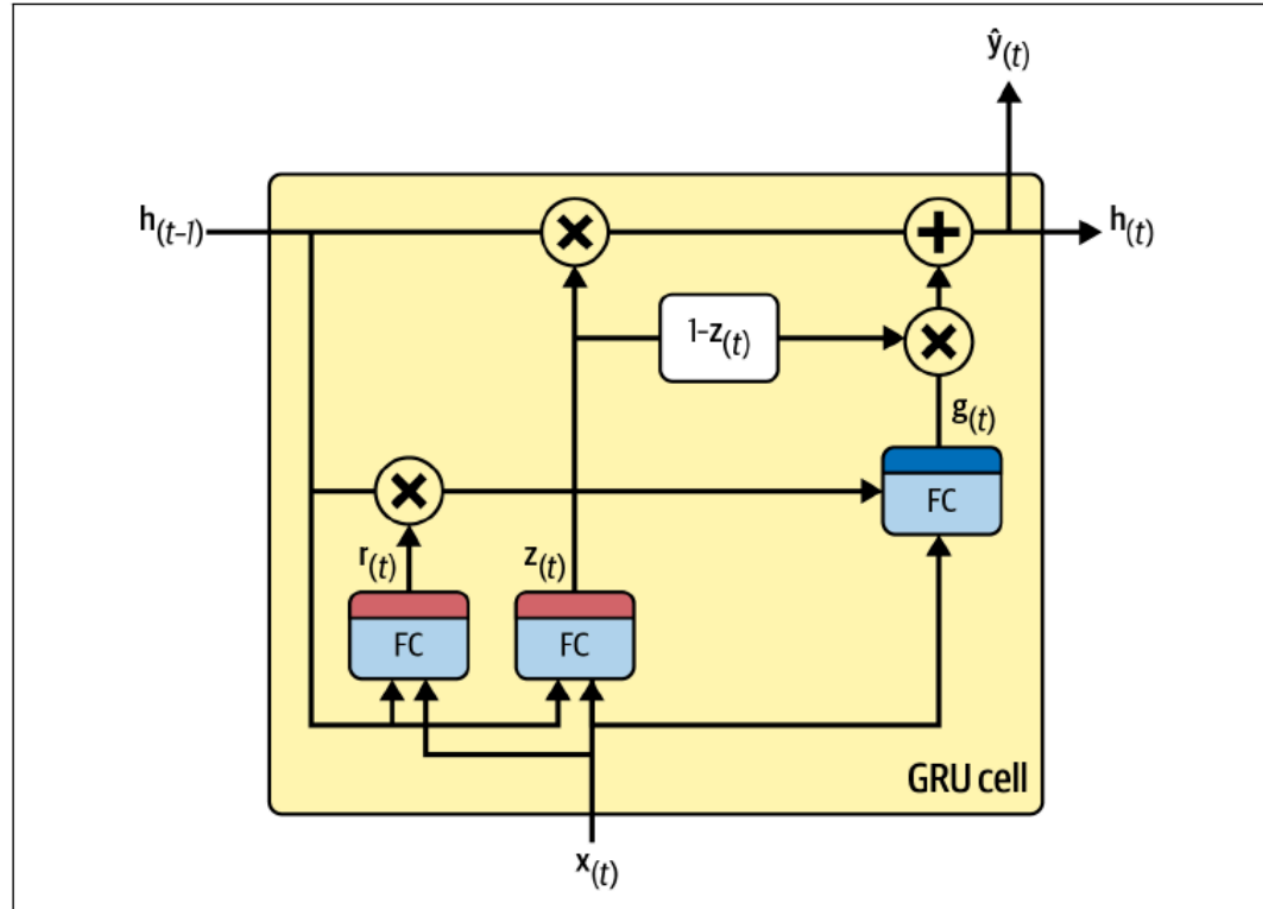

Figure 15-13. GRU cell

Next up: Natural Language Processing

Preview: Natural Language Processing

- Natural Language Processing (NLP) is a field of study that focuses on the interaction between computers and human language.
- RNNs are widely used in NLP tasks such as language modeling, machine translation, sentiment analysis, and text generation.
- Language modeling involves predicting the next word in a sequence of words, which can be done using RNNs.
- Machine translation uses RNNs to translate text from one language to another.
- Sentiment analysis aims to determine the sentiment or emotion expressed in a piece of text, and RNNs can be used for this task.
- Text generation involves generating new text based on a given input, and RNNs are commonly used for this purpose.

Preview: Natural Language Processing

- What is Natural Language Processing (NLP)?
- Common NLP tasks:
 - Language modeling
 - Machine translation
 - Sentiment analysis
 - Text generation
- How RNNs are applied in NLP

Preview: Natural Language Processing

- NLP in 2026 is dominated by **large language models (LLMs)** like GPT-4o, Claude, and Gemini
- Transformer-based architectures have largely **replaced RNNs** for most NLP tasks
- Key capabilities of modern NLP systems:
 - Multi-modal understanding (text, images, audio, video)
 - Long-context reasoning (millions of tokens)
 - Agentic behaviour: tool use, planning, and self-correction
- **?** If transformers have replaced RNNs, why are we still studying them?